

Series 4000SS

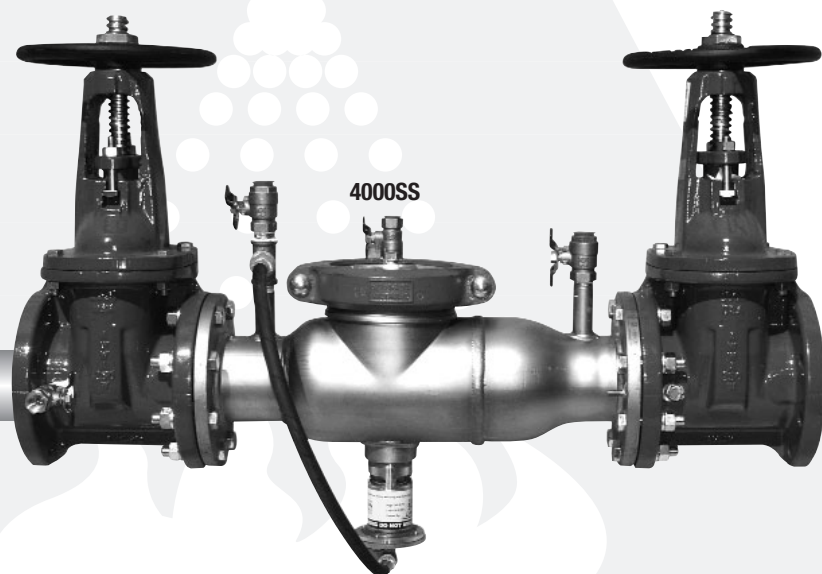

Reduced Pressure Zone Assemblies & Reduced Pressure Detector Assemblies

Sizes: 2 1/2" – 6" (65 – 150mm)

- Installation
- Service
- Repair Kits
- Maintenance

For other repair kits and service parts, send for Ames Repair Parts Price List, PL-A-RP-BPD.

For technical assistance, contact your local Ames representative.

IMPORTANT: Inquire with governing authorities for local installation requirements.

NOTE: For Australia and New Zealand, line strainers should be installed between the upstream shutoff valve and the inlet of the backflow preventer.

It's important that this assembly be tested periodically in compliance with local codes, but at least once per year or more as service conditions warrant. If installed on a fire sprinkler system, all mechanical checks, such as alarm checks and backflow preventers, should be flow tested and inspected internally in accordance with NFPA 13 and NFPA 25.

Limited Warranty: Ames Fire & Waterworks (the "Company") warrants each product to be free from defects in material and workmanship under normal usage for a period of one year from the date of original shipment. In the event of such defects within the warranty period, the Company will, at its option, replace or recondition the product without charge.

THE WARRANTY SET FORTH HEREIN IS GIVEN EXPRESSLY AND IS THE ONLY WARRANTY GIVEN BY THE COMPANY WITH RESPECT TO THE PRODUCT. THE COMPANY MAKES NO OTHER WARRANTIES, EXPRESS OR IMPLIED. THE COMPANY HEREBY SPECIFICALLY DISCLAIMS ALL OTHER WARRANTIES, EXPRESS OR IMPLIED, INCLUDING BUT NOT LIMITED TO THE IMPLIED WARRANTIES OF MERCHANTABILITY AND FITNESS FOR A PARTICULAR PURPOSE.

The remedy described in the first paragraph of this warranty shall constitute the sole and exclusive remedy for breach of warranty, and the Company shall not be responsible for any incidental, special or consequential damages, including without limitation, lost profits or the cost of repairing or replacing other property which is damaged if this product does not work properly, other costs resulting from labor charges, delays, vandalism, negligence, fouling caused by foreign material, damage from adverse water conditions, chemical, or any other circumstances over which the Company has no control. This warranty shall be invalidated by any abuse, misuse, misapplication, improper installation or improper maintenance or alteration of the product.

Some States do not allow limitations on how long an implied warranty lasts, and some States do not allow the exclusion or limitation of incidental or consequential damages. Therefore the above limitations may not apply to you. This Limited Warranty gives you specific legal rights, and you may have other rights that vary from State to State. You should consult applicable state laws to determine your rights. **SO FAR AS IS CONSISTENT WITH APPLICABLE STATE LAW, ANY IMPLIED WARRANTIES THAT MAY NOT BE DISCLAIMED, INCLUDING THE IMPLIED WARRANTIES OF MERCHANTABILITY AND FITNESS FOR A PARTICULAR PURPOSE, ARE LIMITED IN DURATION TO ONE YEAR FROM THE DATE OF ORIGINAL SHIPMENT.**

SILVER BULLET

Installation Instructions

Please Read Prior to Installation:

1. Before installing any Ames assembly, **Flush the Line thoroughly** to remove all debris, chips and other foreign objects. Failure to do so may make the assembly inoperable.
2. The Ames 4000SS and 5000SS Reduced Pressure Zone Assemblies are approved by ASSE (American Society of Sanitation Engineers) to be installed in horizontal positions. **Local water authorities must approve all installation configurations.**
3. **Allow sufficient clearance around the installed assembly to conduct testing,** servicing, and inspection. Allow a minimum of 12" from the flood level to the bottom of the assembly.
4. The 4000SS and 5000SS are not recommended for pit installations. Where necessary, an Air Gap drain may be connected to the relief valve to minimize flooding of the surrounding area. Flooding may cause a cross-connection. **Be sure to contact local code authorities for proper installations.**
5. If installing on fire protection system, be sure to purge air from fire system. Fill system slowly with all inspectors test valves open.

Installation note: The flange gasket bolts for the gate valves should be retightened during installation as the bolts may have loosened due to storage and shipping.

Attention Installer: After installation, please leave this Instruction Sheet for occupant's information.

Note: Assembly body should not be painted.

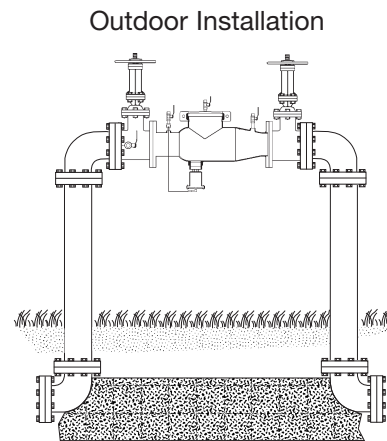
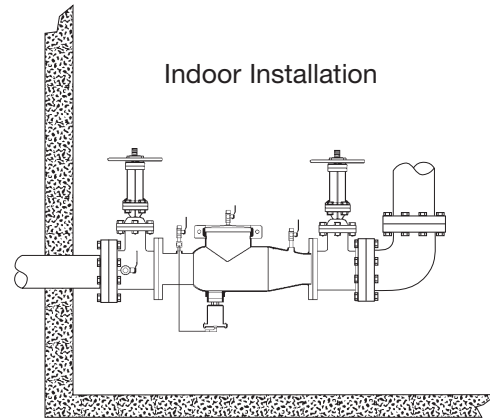

Detailed Parts Listing

Parts Table #1		Ames Part No.				
Item #	Description	Qty	2 1/2" (65mm)	3" (80mm)	4" (100mm)	6"SS (150mm)
1.	#1 Cam-Check	1	7015561	7015561	7015561	7015566
2.	#2 Cam-Check	1	7015560	7015560	7015560	7015565
3.	#1 Cam-Check O-ring	1	7015333	7015333	7015333	7013280
4.	#2 Cam-Check O-ring	1	7013229	7013229	7013229	7013281
5.	Cover Plate	1	7013241	7013241	7013241	7013289
6.	Ball Valve	2	7014668	7014668	7014668	7014668
7.	Groove Coupler	1	7013194	7013194	7013194	7013287
8.	Groove Coupler Gasket	1	7013248	7013248	7013248	7013308
9.	Relief Valve (Complete assembly)	1	7013354	7013354	7013354	7013354
10.	Relief Valve Hose	1	7013343	7013343	7013343	7013343
11.	Relief Valve Body O-ring	1	A400084	A400084	A400084	A400084

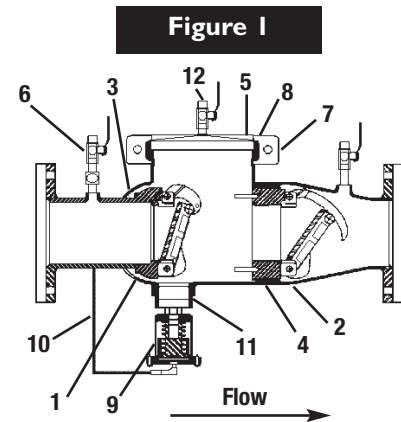

Figure 2

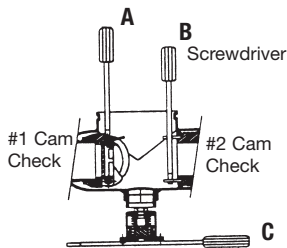

Figure 3

#1 Cam Check
2 1/2" - 6" (65-150mm) RP (Short Cam)

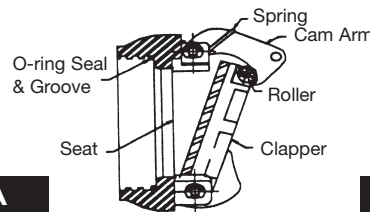

Figure 4

#2 Cam Check DC & RP

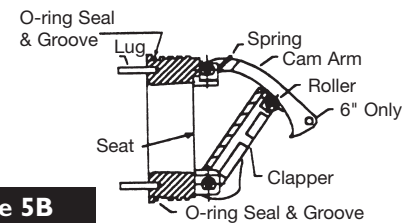

Figure 5A

Cam Bar Open Pin

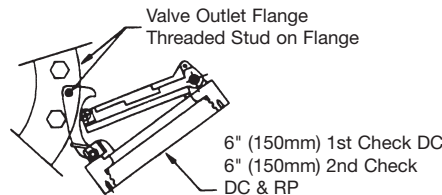

Figure 5B



Maintenance Instructions

NOTE: Ames assemblies require minimum maintenance. All assemblies must be retested once maintenance has been performed. Before servicing be certain shutoff valves are closed.

Removing Cam-Checks

- Shut down water system and lock out system if possible. Slowly open all ball valves to relieve air and water pressure. Loosen bolts on groove coupler and remove groove coupler and cover plate from valve body.
- Remove #1 Cam-Check Assembly by using your hands to unscrew (turn counter-clockwise) Cam-Check and remove through top access port. **Do not use Cam Arm as a handle to unscrew Cam-Check.** If Cam-Check cannot be loosened by hand, insert a long screwdriver between valve body and Cam-Check (see figure 3). Gently apply pressure against the Cam-Check until loosened. Finish unscrewing by hand. Unscrew #2 Cam-Check (turn counter-clockwise) by placing a long screwdriver across lugs and applying pressure to loosen #2 Cam-Check. Finish unscrewing by hand.
- To clean #1 Cam-Check (except 2 1/2" - 4" (65-100mm) DC Check), locate the Cam Arm opening stud on the outlet flange of the valve assembly. Slide the Cam Arm over the

stud with the check threads facing downward (figure 5A). Tighten 1/4" nut on stud to secure cam bar. Slowly pull the assembly outward to open check allowing exposure of the seat and clapper contact area for cleaning. To clean #2 Cam-Check, lift Cam Arm and hold in open position. Raise clapper so that the end of the Cam Arm rests between roller and clapper (figure 5B). Thoroughly clean the seat area and clapper sealing surfaces of both Cam-Checks. Rinse Cam-Checks and O-rings thoroughly. Inspect seats, clapper sealing surfaces, Cam Arms, and O-rings for damage, nicks, and debris. If not damaged, gently close the clapper. If damaged, install a new Cam-Check assembly and/or O-ring or shutoff disc.

- Before reinstallation of check assembly, thoroughly clean O-ring groove and lubricate with F.D.A. approved lubricant. Insert and thread #2 Cam-Check first and then #1 Cam-Check. #2 Cam-Check should be tightened by inserting a long screwdriver between lugs to tighten firmly (see figure 2). Do not over tighten. Tighten #1 Cam-Check firmly by hand only. Replace cover plate, clean groove coupler gasket and groove. Replace groove coupler. Close ball valves. Repressurize and bleed air from all test cocks.

Relief Valve Service Instructions

1. The relief valve may be serviced while on or off the backflow preventer valve.
2. **Note: Do not use a pipe wrench to remove the relief valve assembly from the backflow preventer.**
3. Shut down water system.

Relief Valve Disassembly

1. Disconnect the relief valve hose from the elbow in the bottom flange cover at the swivel hose connection. Do not remove the elbow.
2. If the valve is to be removed from the backflow preventer for service, place a screw driver blade or flat bar across the edges of (2) of the hex head screws in the bottom flange cover and turn counter-clockwise to loosen the relief valve assembly. (see Figure 2)
3. Remove the (4) bottom bolts from the bottom of the relief valve assembly with a $\frac{5}{16}$ " socket or open-end wrench. Remove the bottom flange cover.
4. Remove the piston assembly & sleeve from the relief valve body by placing your index fingers through the slots in the side of the body and pressing down on the top of the disc retainer in the top of the piston assembly. (See Figure 7.)
5. Pull the piston assembly free of the body by grasping the sleeve and pulling down.
6. Grip the sleeve and the piston assembly by the head of the hex head bolt. Pull up on the sleeve to extend the diaphragm. Slide the sleeve (Part #7013340) completely off of the diaphragm and inspect the diaphragm for tears, holes or excessive wrinkles. If the diaphragm is damaged, order a new piston/diaphragm assembly.

Relief Valve Reassembly

1. Thoroughly clean all inside surfaces of the relief valve body.
2. Inspect the relief valve body seat surface located at the top edge of the (3) discharge slots near the top of the body by rubbing the end of the index finger around the entire seat surface; access the seat surface through the slots or the bottom of the body. The seat must be free of nicks. If nicks are discovered, remove the body & install a new relief valve assembly.
3. Position the diaphragm on the piston assembly so that it is facing up as shown in Figure 8.
4. Now fold the top (ribbed) edge of the diaphragm inward, grasp the sleeve with the ribbed edge up and slide the sleeve down over the piston assembly as shown in Figure 8.
5. While still holding the sleeve, slide it up over the diaphragm and, using your thumb & index finger, position the bead of the diaphragm so that it wraps over the outside of the rib on the top of the sleeve so that the sleeve is held by the diaphragm. Now place the piston assembly on a flat, firm surface with diaphragm facing up as shown in Figure 9.
6. Cup your hand slightly to form an air trap and force the sleeve down over the piston assembly with a rapid slap (hard) on the open end of the diaphragm with your cupped

hand. The trapped air in the diaphragm will force the diaphragm between the inside of the sleeve and the outside of the piston. Ensure that the diaphragm is fully seated by running the end of a dull "butter" knife in the formed diaphragm. If diaphragm is wrinkled, repeat previous step.

7. Slide the piston assembly and sleeve into the relief valve body with the hex head bolt entering the flanged end of the body first. Slide the piston assembly in until the diaphragm lip is smoothly seated in the machined groove in the flanged end of the body. By running your index finger around the outside of the diaphragm bead, you will ensure it is seated smoothly.
8. Position the bottom flange cover on the bottom of the relief valve body and secure by hand tightening the (4) bottom bolts.
9. Now tighten the (4) bottom bolts to approximately 15 ft.-lbs. with a $\frac{5}{16}$ " socket or open-end wrench.
10. Reattach the relief valve hose to the elbow in the bottom flange cover.

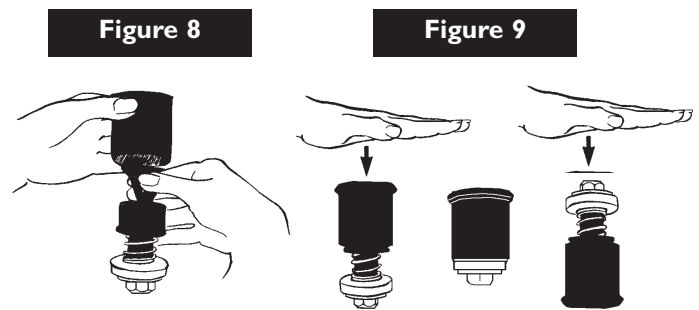
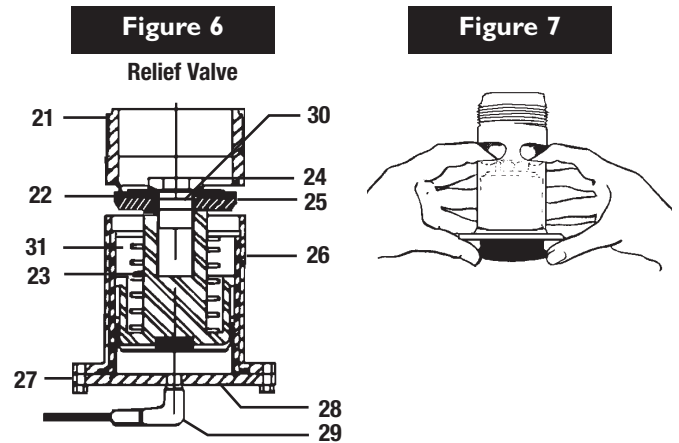

Parts Table #2			
Item #	Part Description	Qty	Ames Part No.
21.	Relief Valve Body	1	7013337
22.*	Rubber Shut-Off Disc.	1	7013330
23.*	Piston Diaphragm Assembly	1	7013352
24.	Hex Head Bolt	1	7013326
25.	Disc. Retainer	1	7013328
26.	Sleeve	1	7013340
27.	Bottom Bolt	1	7012545
28.	Bottom Flange (w/St. Elbow)	1	7013339
29.	Elbow St 90 3/8	1	A403609
30.*	O-Ring Disk	2	7013327
31.	RV Spring	1	7013368
Not Shown - RV Rubber Kit (Includes * Items and Body O-Ring.)			7018897